



# The Cyclone II Spraybooth

## Dimensions

Internal: 7.2m x 4.0m x 2.5m

External: 7.3m x 4.1m x 3.0m

Additional height options of 3.0m, 3.5m & 4.0m (internal)

## Lighting

STL's unique air-cooled light pods provide luminance in excess of 1500 Lux with just 18 light tubes (standard length booth). High frequency electronic ballast reduces energy consumption by 50% over traditional ballast.

## Inlet Filter System

True wall-to-wall inlet filter plenum ensures uniform airflow throughout cabin. High efficiency filter ensures clean air to 7 microns.

## Underfloor Extraction

2m x 7m gridded pit complete with standard duplex filtration  
Optional fully gridded floor or raised floor complete with LPex even extraction system. Option of sidewall extraction.

## LPex

Unique Local Points of Extraction system ensures fully gridded and raised floors extract evenly throughout the cabin, without resorting to the traditional method of using crude steel plates.



## AquaDry Air Agitation (option)

High-level nozzles, operating from above the spray area, direct pre-heated filtered air into the cabin for rapid flash-off and drying of all waterborne paints and solvent-based clear/topcoat.

## Economy Stand-By Mode

Automated energy-saving standby mode included with standard specification, whereby the booth automatically reduces fan speed to tick over when the booth detects no spraying is taking place.

## Clearance Indicator System

Included as standard specification. Amber beacons indicate when spraying is in progress, and automatically switch off once the clearance time of the spraybooth has elapsed, indicating the booth is now free of hazardous isocyanite.

## Construction

Durable double-skinned and insulated  
2-leaf main doors with large glass viewing panel

## Vehicle Access

Standard 2.5 x 2.5m durable 2-leaf door system with large viewing panel. Options of 3-leaf, corner doors, roller shutter doors and additional set of doors for drive-through capability.

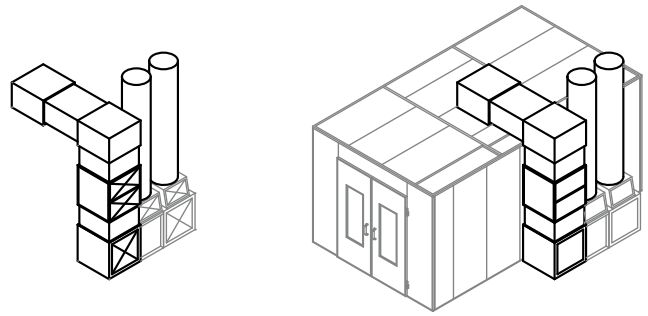

## Air Handling Plant

Floor or roof-mounted, 230kW fully-modulating duct burner  
Direct gas-fired - natural gas or LPG. Optional indirect oil fired burner.

## Mixed Flow Fan System

Unique to STL, these direct drive, maintenance free fans combine efficiency and consistency and are exceptionally quiet in operation.

5.5kW system 24,000m<sup>3</sup>/hr

7.5kW system 33,000m<sup>3</sup>/hr

## Control Panel

Sophisticated technology with a robust, operator-friendly interface. Automates temperature, pressure and time control for five different modes of operation, including standby, spray, flash off, bake and cool down.

## Noise Levels

Comfortable working cabin noise levels of less than 75dBA.

## Service and support

Quality nationwide coverage, with regionally based Corgi-registered engineers providing service back-up and customer support.

## Warranty

Standard 12-month warranty.

Optional 3 year warranty with service package.

## On site Services required

5.5kW fan system - 32A 3-phase & neutral  
(max running current -22A)

Gas supply – max 480ft<sup>3</sup>/hr.

7.5kW fan system - 45A 3-phase and neutral

(max running current 30A)

Gas supply – max 600ft<sup>3</sup>/hr